

FURLEX

SELDÉN

Spare Parts List
Furlex 50 S

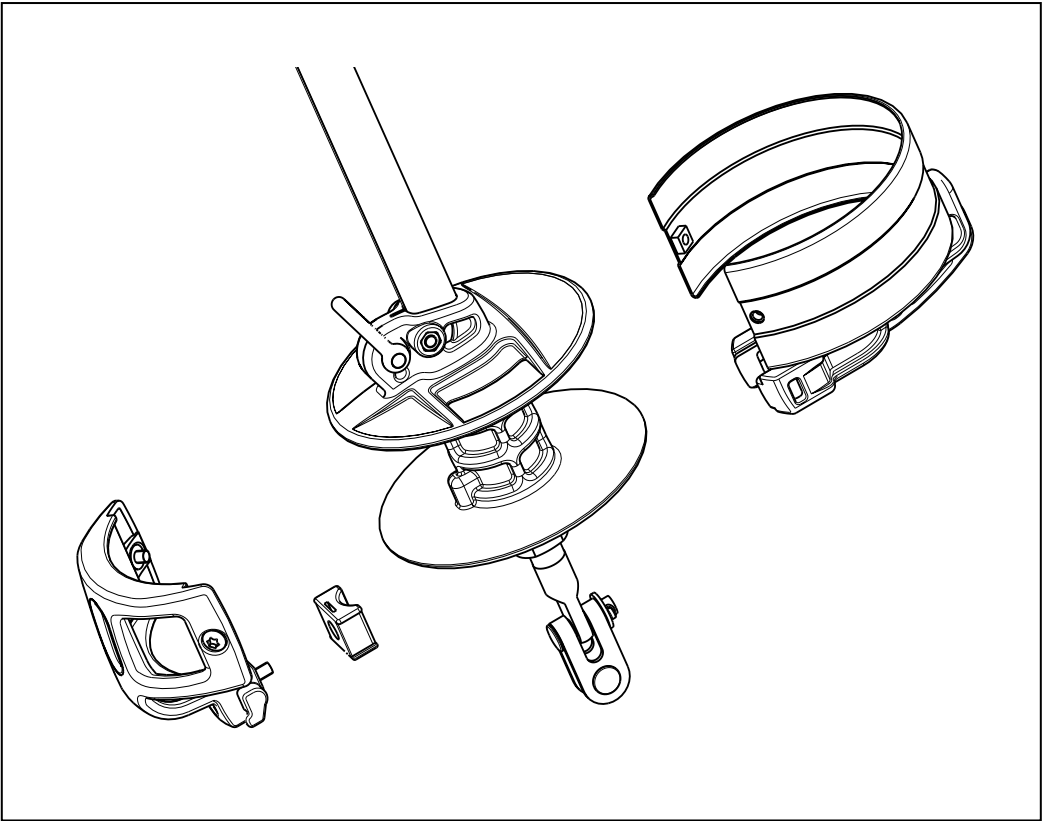

SELDÉN

Bäste Furlex-ägare

Furlex säljs genom ett nät av auktoriserade återförsäljare som täcker alla marina marknader runt om i världen.

Auktorisationen omfattar praktisk och teoretisk utbildning i hur Furlexsystemet är uppbyggt.

Denna kunskap innebär professionell service till Dig som Furlexägare.

Vi önskar dig mycket skön segling och hoppas att denna reservdelslista kan vara till nytta om du någon gång behöver kontakta en återförsäljare för professionella råd eller assistans.

Dear Furlex-owner

Furlex is supplied via an extensive network of authorized dealers who cover the major sailing areas of the world.

The authorization ensures that each dealer is fully versed in the design, assembly and operation of Furlex - and is a guarantee of professional service. We wish you much enjoyable and carefree sailing and hope that this spare parts list will be of help if you ever require professional advice or assistance.

Lieber Furlex-Eigner

Furlex wird über ein Netz autorisierter Fachhändler weltweit in allen Segelregionen verkauft.

Die Autorisierung dieser Fachhändler erfolgt durch eine theoretische und praktische Schulung im Aufbau des Furlex-Systems.

Dieses Können gewährleistet Ihnen als Furlex-Besitzer professionellen Service.

Wir wünschen Ihnen ein angenehmes Segeln und hoffen, daß Ihnen dieses Ersatzteilverzeichnis hilft bei eventuellem Bedarf eines Rates oder professioneller Hilfe.



OBS!

Plocka ej isär fallsvirveln eller nedre lagringsdelen. Det kan vara svårt att återmontera dessa delar på ett korrekt sätt. Bland annat ligger lagerbanornas kulor löst monterade. Vid behov av service, kontakta din Furlexåterförsäljare.



NOTE!

Do not dismantle the halyard swivel or lower bearing assembly. You will find it difficult to re-assemble them correctly (the ball-bearings are loose and difficult to refit!). Contact your Furlex dealer if service is required.



ACHTUNG!

Nehmen Sie den Fallschlitten oder die untere Lagerung nicht auseinander. Es ist schwer diese wieder korrekt zu montieren. Unter anderem liegen die Kugeln lose montiert. Wenden Sie sich bei Bedarf an Ihren Furlex- Händler.

Seldén Mast AB reserves the right to alter the design or specification without prior warning; to allow unrestricted future product development.

Contents

	<i>Page</i>
<i>Halyard swivel</i>	4
<i>Lower swivel</i>	6
<i>Line guard bracket assembly</i>	8
<i>Line guide fitting assembly</i>	8
<i>Additional Items</i>	10
<i>Luff extrusions</i>	12
<i>Notes</i>	14

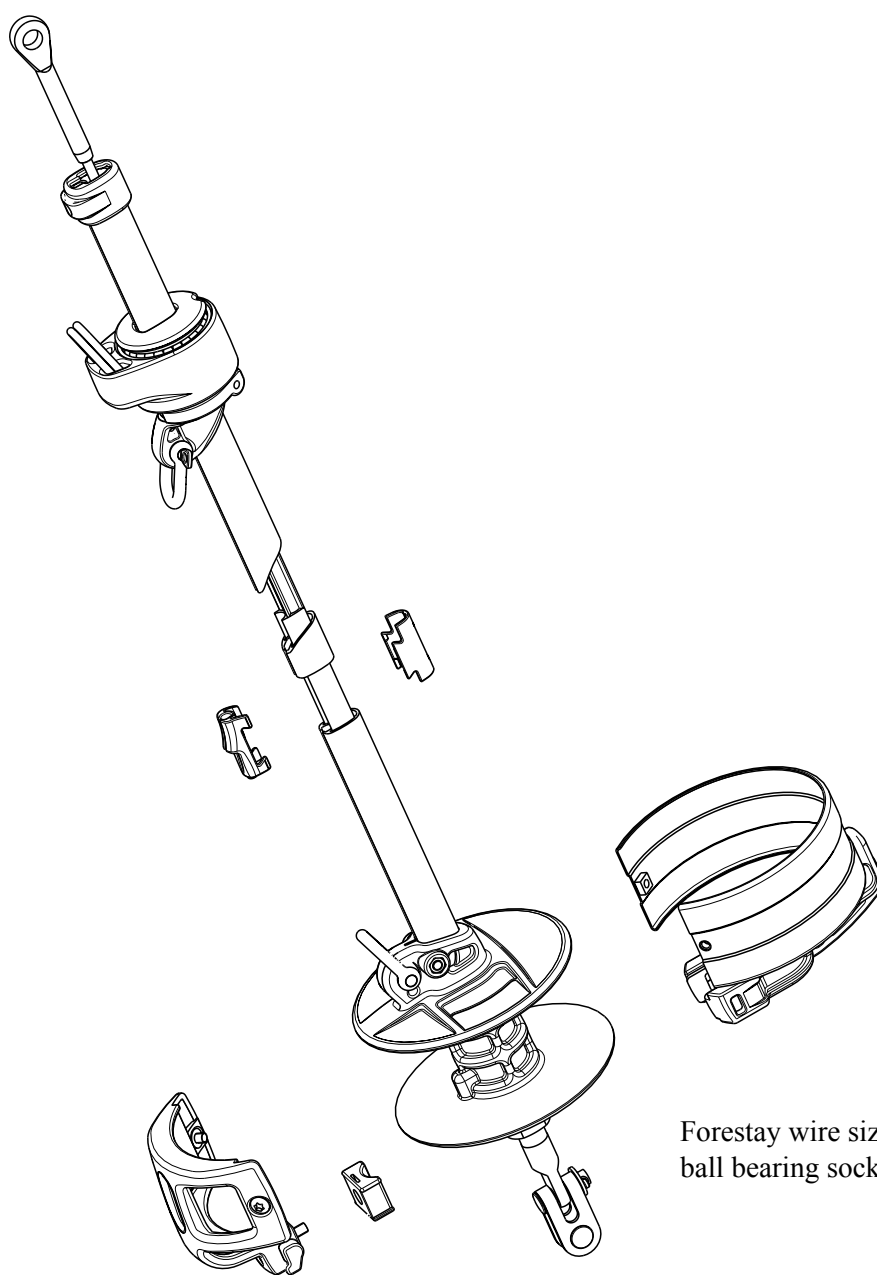

Forestay wire size is marked at the ball bearing socket. (Item B11).

Halyard swivel

Description A

				Forestay wire size	
Item	Description	Dimension	Qty	Ø 4 mm	Ø 5 mm
		Assembly number	→	539-333-01	539-333-01
A1	Hub - Halyard swivel	Ø 49x80	1	539-333	539-333
A2	Ball bearing ring - inner	Ø 44x5	2x1	539-337	539-337
A3	Balls	Ø 5	2x25	539-033	539-033
A4	Ball bearing ring - outer	Ø 51x7	2x1	539-336	539-336
A5	Eye Ring	Ø 55x33	1	539-334	539-334
A6	Collar	Ø 44x8	1	539-335	539-335
A7	Selftapping screw	4.2x19	1	171-040	171-040
A8	Shackle	Ø 6x13x24	1	307-082	307-082
A9	Halyard lashing	HMPE Ø 4	0.5 m	613-051	613-051

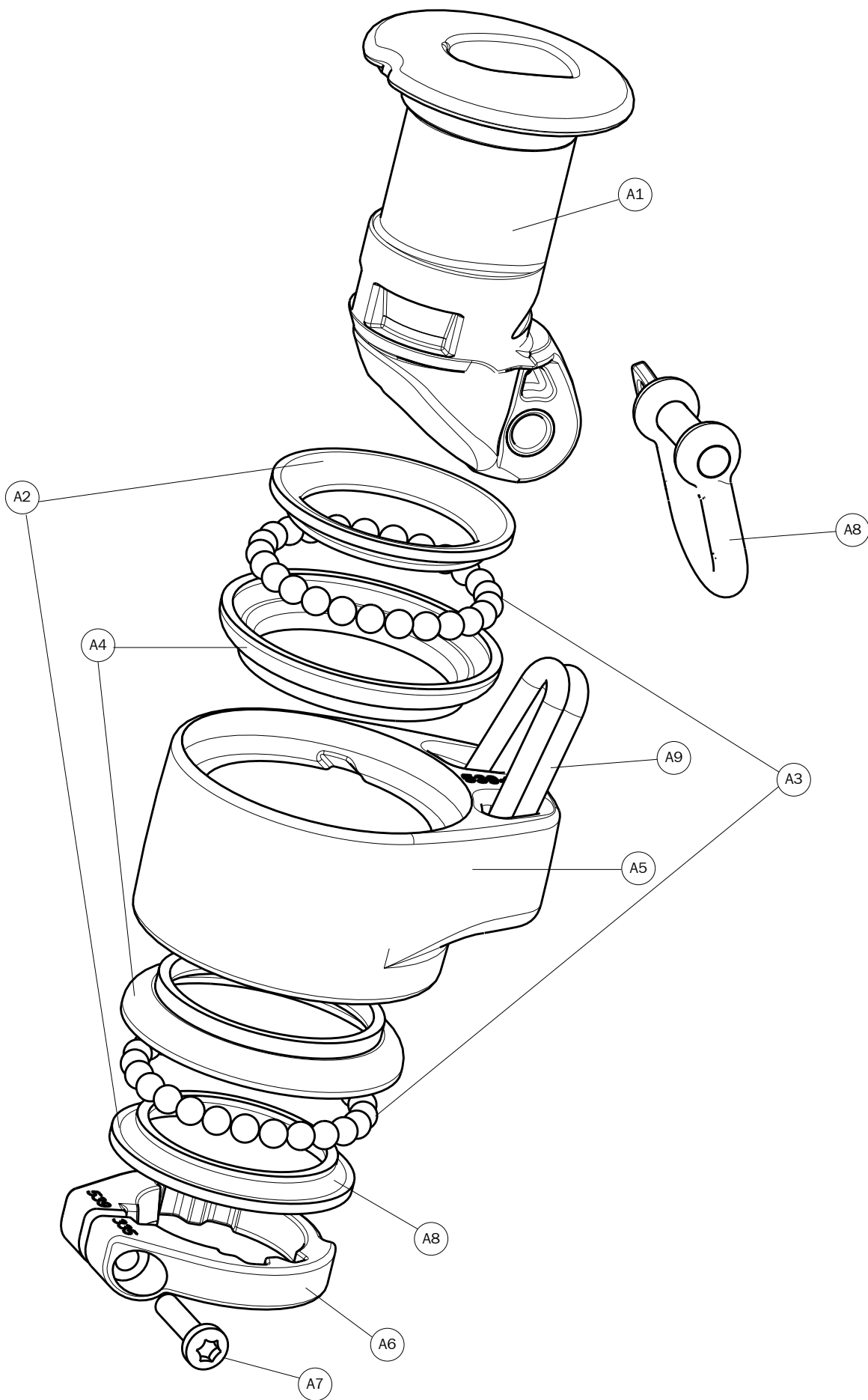

Lower swivel

Description B

Item	Description	Dimension	Qty	Forestay wire size	
				Ø 4 mm	Ø 5 mm
		Assembly number	→	539-326-02	539-326-03
B1	Drum	Ø 125x100	1	539-326 ¹⁾	539-326 ¹⁾
B2	Screw	5x30	1	155-649	155-649
B3	Locking nut	M5	1	158-004	158-004
B4	Selftapping screw	4.2x19	1	174-049	174-049
B5	Ball bearing ring - outer	Ø 30x10	2x1	539-311	539-311
B6	Balls	Ø 6	2x10	539-034	539-034
B7	Label, "Furlex"	37x18	1	591-708	591-708
B8	Label, "50S"	37x18	1	591-709	591-709
B9	Ball bearing tube	Ø 13.5x77	1	539-327 ²⁾	539-327 ²⁾
B10	Grub screw	M6/4.8x8	2	153-103	153-103
B11	Ball bearing socket	Wire Ø marked	1	301-188	301-189
B12	Wedge	Wire Ø 4	1	301-150	-
B12	Wedge	Wire Ø 5	1	-	301-151
B13	Former	Wire Ø 4	1	301-191	-
B13	Former	Wire Ø 5	1	-	301-175
B14	Terminal eye fitting	Ø 14x45	1	301-192 ³⁾	-
B14	Terminal eye fitting	Ø 17x51	1	-	301-176 ³⁾
B15	Toggle/fork/fork	H(c/c)=25	1	517-056 ³⁾⁴⁾	-
B15	Toggle/fork/fork	H(c/c)=30	1	-	517-054 ³⁾⁴⁾
B16	Clevis pin	Ø 8x27	1	165-113 ⁴⁾	-
B16	Clevis pin	Ø 10x35	1	-	165-221 ⁴⁾
B17	Washer	Ø 16/8-1.5	1	165-401 ⁴⁾	-
B17	Washer	Ø 18/10-2	1	-	165-402 ⁴⁾
B18	Split pin	Ø 2.3x12	1	301-047 ⁴⁾	-
B18	Split pin	Ø 2.9x16	1	-	301-049 ⁴⁾
B19	Clevis pin	Ø 8x18	1	165-101 ³⁾⁴⁾	-
B19	Clevis pin	Ø 10x22	1	-	165-202 ³⁾⁴⁾
B20	Split pin	Ø 2.3x12	1	301-047 ³⁾⁴⁾	-
B20	Split pin	Ø 2.9x16	1	-	301-049 ³⁾⁴⁾
B21	Shackle	Ø 6x13x24	1	307-082	307-082

³⁾	Alt. use a standard STA-LOK eye				
¹⁾	Only as a package B1 - B4, B7 - B8	1	539-326-04	539-326-04	
²⁾	Only as a package B9, B10 - B14	1	301-188-03	301-189-03	
³⁾	B15, B19 - B20 also as a package	1	517-056-01	517-054-01	
⁴⁾	B15 - B20 also as a package	1	517-056-02	517-054-02	

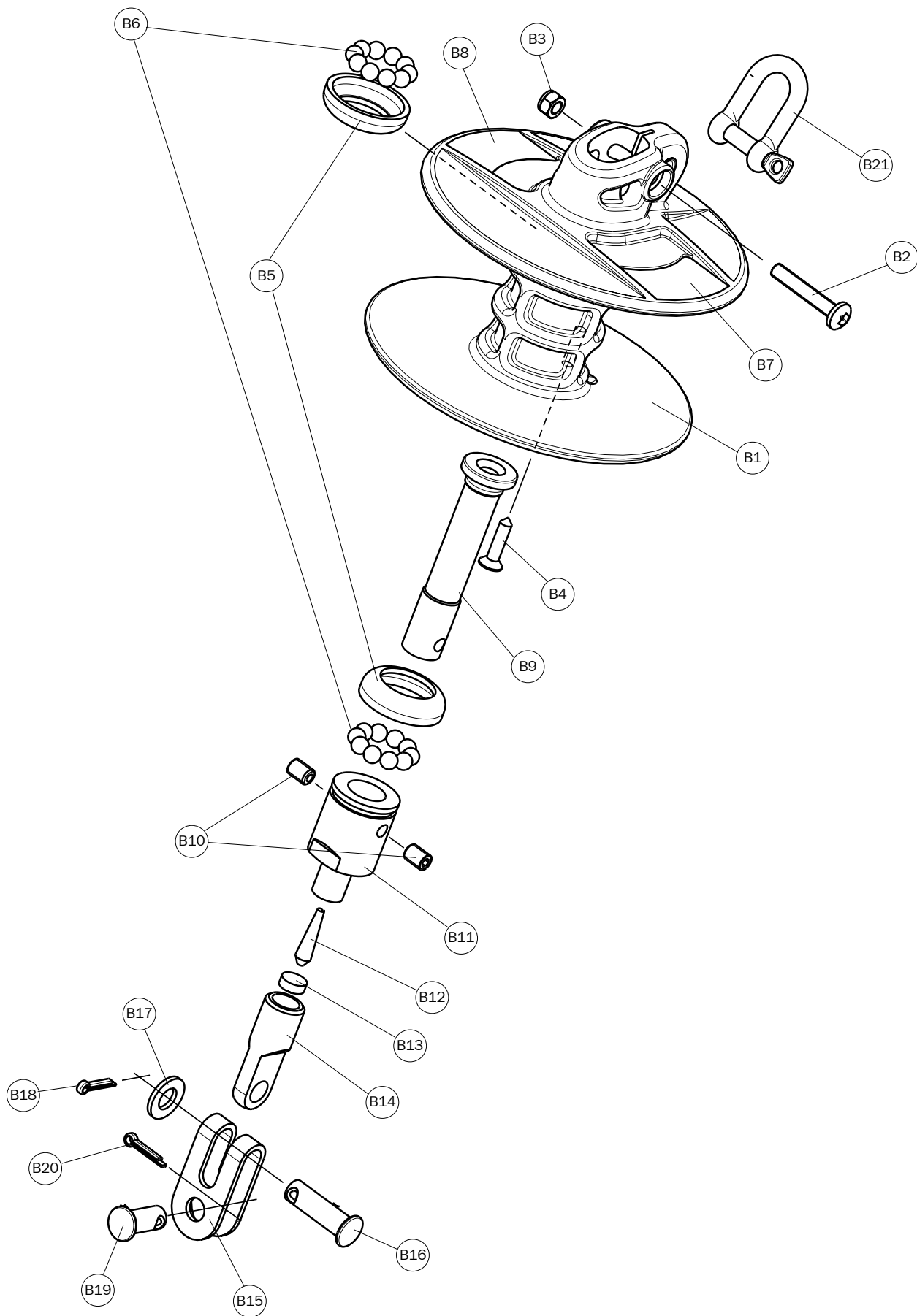

Line guard bracket assembly

Description C

Item	Description	Dimension	Qty	Forestay wire size	
				Ø 4 mm	Ø 5 mm
		Assembly number	→	539-328-01	539-328-01
C1	Line guard bracket	48x115	1	539-328	539-328
C2	Cover	Ø 120x50	1	539-329	539-329
C3	Label	130x15	2	591-711	591-711
C4	Screw	MRT 5x8	1	155-607	155-607

Line guide fitting assembly

Item	Description	Dimension	Qty	Forestay wire size	
				Ø 4 mm	Ø 5 mm
		Assembly number	→	539-330-01	539-330-01
C5	Line guide fitting	110x88	1	539-330 ¹⁾	539-330 ¹⁾
C6	Screw	MRT 5x8	2	155-607	155-607
C7	Retaining washer	10/5-3	2	164-043	164-043
C8	Screw	MRT 5x25	1	155-619	155-619
C9	Square nut	M5	1	164-511	164-511

¹⁾	Only as a package C5 - C9		1	539-330-01	539-330-01
---------------	---------------------------	--	---	------------	------------

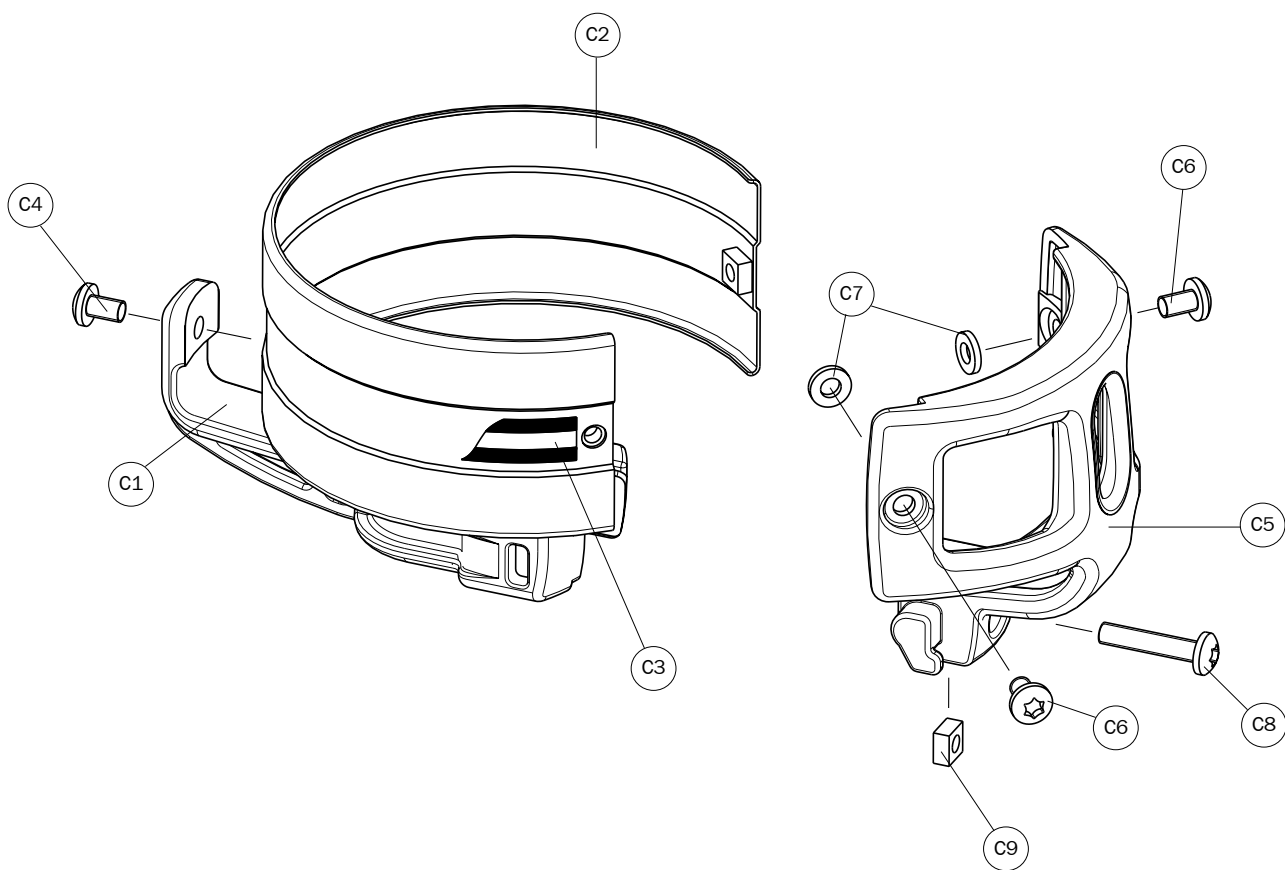

Additional items

Description D

Item	Description	Dimension	Qty	Forestay wire size	
				Ø 4mm	Ø 5 mm
D1	Forestay wire	L=10 500	1	601-002-30	601-002-31
D1	Forestay wire	L=12 900	1	-	601-003-32
D2	Furling line	Ø 6 L=15 000	1	611-001-04	611-001-04

	Halyard lead set	Assembly number	→	508-159-03	508-159-03
D3	Halyard lead	Ø 14-35	1	508-159 ²⁾	508-159 ²⁾
D4	Selftapping screw	MRX-TT 6x12	2	155-703 ²⁾	155-703 ²⁾
D5	Insulator	35x41	1	530-632 ²⁾	530-632 ²⁾

D6	Prefeeder pack		1	505-538-01	505-538-01
D7	Locking adhesive		1	312-305	312-305
D8	Lubricating grease	ca 100 gram	1	312-501	312-501
D9	Stanchion block	For Ø 25 mm	1	538-971-01	538-971-01
D9	Stanchion block (4-pack)	For Ø 25 mm	4	538-971-02	538-971-02
D10	Manual (English text)	A4	1	595-982-E	595-982-E
D10	Manual (Swedish text)	A4	1	595-982-S	595-982-S
D10	Manual (German text)	A4	1	595-982-T	595-982-T
D11	Spare parts list	A4	1	595-983-E	595-983-E

		Assembly number	→	539-356-01	539-356-01
D12	Top guard	Ø 39x50	1	539-356 ¹⁾	539-356 ¹⁾
D13	Screw	RTS 4.2x9.5	1	171-056	171-056

D14	Drillbit	Ø 5.3	1	592-006 ²⁾	592-006 ²⁾
-----	----------	-------	---	-----------------------	-----------------------

¹⁾	Only as a package D12-D13		1	539-356-01	539-356-01
²⁾	Only as a package D3-D5, D14		1	508-159-03	508-159-03

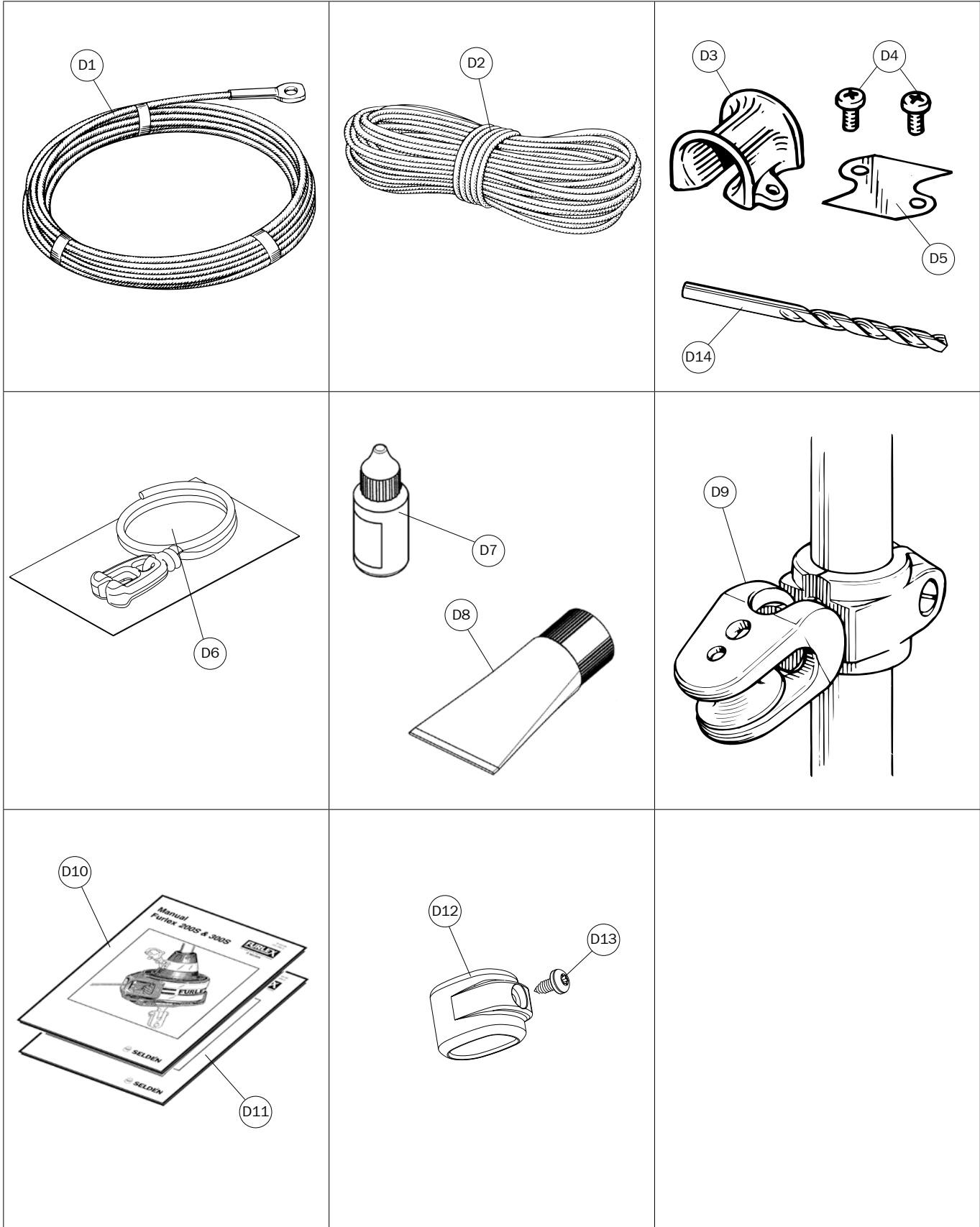

Luff extrusion 600mm**Description E**

Item	Description	Dimension	Qty	Forestay wire size	
				Ø4mm	Ø5mm
		Assembly number	→	539-361-01	539-361-01
E1	Luff extrusion	22x15 L=600	1	539-361	539-361
E2	Distance tube	12x10 x 535	1	539-348	539-348
E3	Sail feeder	35x16	1	539-357 ²⁾	539-357 ²⁾
E4	Sail feeder connector	35x16	1	539-342 ²⁾	539-342 ²⁾
E5	Connection plate	80x7	1	539-353	539-353

Luff extrusion 2000mm

		Assembly number	→	539-362-01	539-362-01
E6	Luff extrusion	22x15 L=2000	1	539-362	539-362
E7	Distance tube	12x10 x L=1900	1	539-349	539-349
E8	Joint sleeve	11x10 L=200	1	539-364	539-364
E9	Connection plate	45x7	1	539-351	539-351

Luff extrusion 2400mm

		Assembly number	→	539-363-01	539-363-01
E10	Luff extrusion	22x15 L=2400	1	539-363 ¹⁾	539-363 ¹⁾
E11	Distance tube	12x10 x2200	1	539-350 ¹⁾	539-350 ¹⁾
E12	Joint sleeve	11x10 L=200	1	539-364 ¹⁾	539-364 ¹⁾
E13	Connection plate	45x7	1	539-351 ¹⁾	539-351 ¹⁾
¹⁾	E10-E13 also as a package		1	539-363-05	539-363-05
²⁾	Only as an assembly E3-E4		1	539-357-01	539-357-01

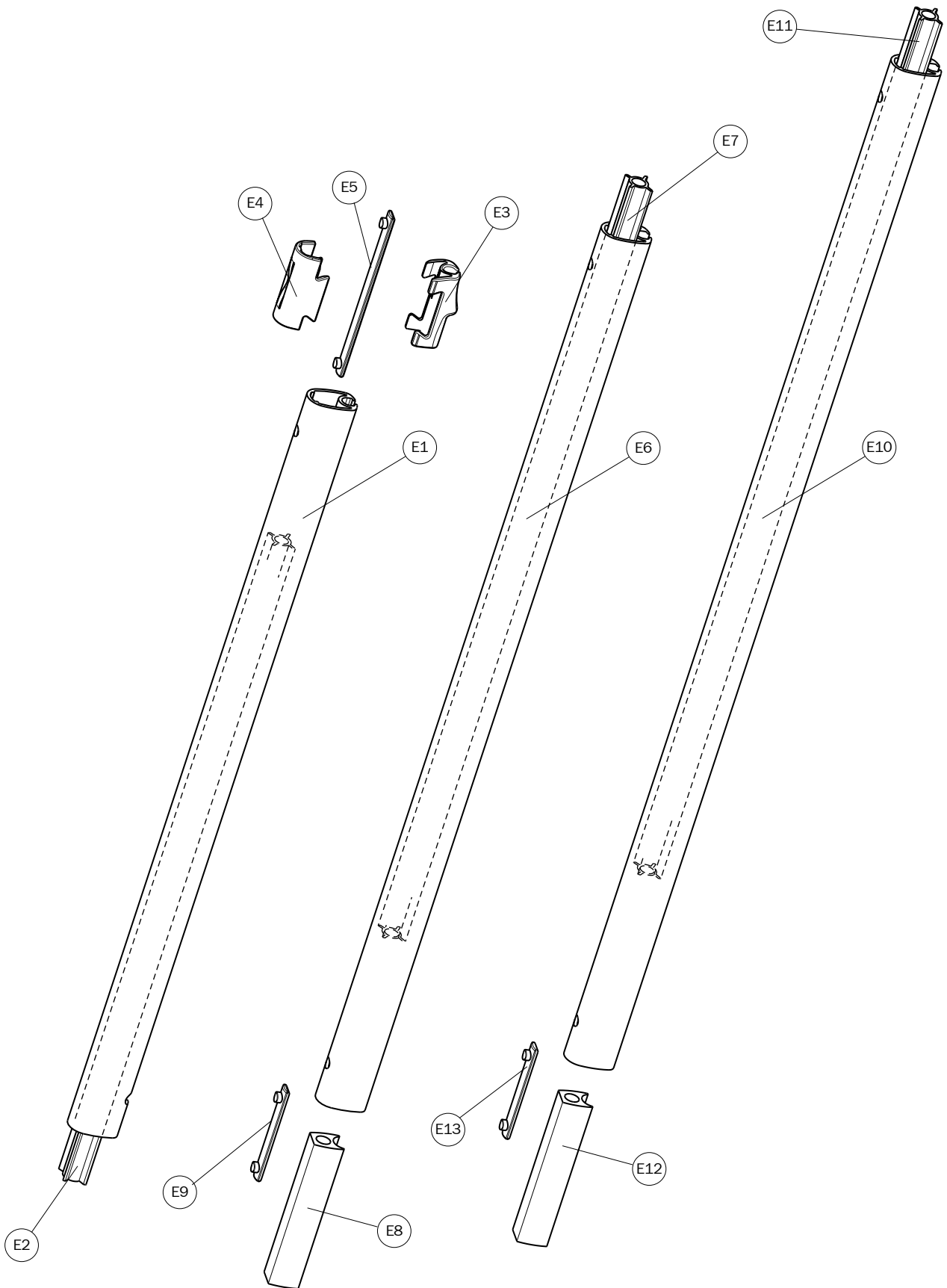

DINGHIES KEELBOATS YACHTS

Seldén Mast AB, Sweden
 Tel +46 (0)31 69 69 00
 Fax +46 (0)31 29 71 37
 e-mail info@seldenmast.com

Seldén Mast Limited, UK
 Tel +44 (0) 1329 504000
 Fax +44 (0) 1329 504049
 e-mail info@seldenmast.co.uk

Seldén Mast Inc., USA
 Tel +1 843-760-6278
 Fax +1 843-760-1220
 e-mail info@seldenus.com

Seldén Mast A/S, DK
 Tel +45 39 18 44 00
 Fax +45 39 27 17 00
 e-mail info@seldenmast.dk

Seldén Mid Europe B.V., NL
 Tel +31 (0) 111-698 120
 Fax +31 (0) 111-698 130
 e-mail info@seldenmast.nl

Seldén Mast SAS, FR
 Tel +33 (0) 251 362 110
 Fax +33 (0) 251 362 185
 e-mail info@seldenmast.fr

www.seldenmast.com

Dealer:



J.S. Elcano, 6, 03730 JAVEA (Alicante)
 Tel. 96 646 12 11 · Fax: 96 646 12 13
www.blaumar.com

 **SELDÉN**

The Seldén Group is the world's leading manufacturer of masts and rigging systems in carbon and aluminium for dinghies, keelboats and yachts. The Group consists of Seldén Mast AB in Sweden, Seldén Mast A/S in Denmark, Seldén Mast Ltd in the UK, Seldén Mid Europe B.V. in the Netherlands, Seldén Mast SAS in France and Seldén Mast Inc in the USA. Our well known brands are Seldén and Furlex. The worldwide success of Furlex has enabled us to build a network of over 750 authorised dealers covering the world's marine markets. So wherever you sail, you can be sure of fast access to our service, spare parts and know-how.